

Smoothing control of load frequency fluctuation using frequency controlled pitch controller

¹ A.H.M Iftekharul Ferdous, ² M. R. I. Sheikh, ³ Md.Asaduzzaman Shobug, ⁴ Tonmoy Ghosh

^{1,3,4} Dept. of EEE, Pabna University of Science and Technology

² Dept. of EEE, Rajshahi University of Engineering and Technology

Abstract— Among many energy resources present on the earth, wind is the most vital source can be used for the generation of the electricity. But frequency fluctuation is the main concern for the power grid companies due to their adverse effect on industrial applications and with the random varying wind speed, fluctuation of the frequency occurs. For this reason many pitch controller have been used, however they decreases the energy generation. This paper focuses on designing a new pitch controller which is designed with rotor speed and frequency for controlling the wind generator output power fluctuation and minimizes the frequency fluctuations. The whole simulation analysis have been performed by using PSCAD/EMTDC [6] and real wind speed data is used for this analysis.

Index Terms— Wind Farm; Pitch controller; Frequency fluctuation; LFC; Smoothing Control; PSCAD.

1 INTRODUCTION

Due to the present condition of environmental concern, it is very much needed to use the renewable sources for the generation of electricity rather than using the conventional method. Among these many renewable sources present on the earth, wind energy is the most important for the electricity generation because it is very safe, non-polluting and available in very large scale. A simple way to generate electricity from wind is to use wind turbine and single induction generator such as wind generator can be used for their lossless and brushless and low maintenance cost which can be connected directly to the power grid, because induction generators are the most cost-effective machines for energy conversion. Because of the proportionality of wind turbine output to the cube of the wind velocity, frequency fluctuation occurs due to the variation of wind speed and also the output power fluctuation of wind generator occur which causes several problems on the overall power system as a result inaccuracy and lamp flickering occurs. Thus, for the power system security, it is very much needed to minimize the fluctuations of power system frequency. Several methods for smoothing the wind generator output fluctuations using several types of energy storage systems are proposed at present, such as electric double layer capacitor (EDLC), superconducting magnetic energy storage (SMES)[1-2] etc. for minimizing frequency fluctuations which is too much costly. Many works have already been done depending on the application of SMES for the wind power generation and these energy devices are used to solve the fluctuation issues of the wind power generation system [1, 3-5].

In most of the cases, frequency fluctuation minimization is done by using the energy devices such as SMES in minimizing frequency fluctuations is evaluated considering a multi-machine power system consisting of hydroelectric generators, diesel generators and wind generator [4]. Another control strategy of the STATCOM/SMES is installed at a wind farm for decreasing fluctuations of output power and frequency of the wind farm [5]. But, for the uses of energy storage device, the installation cost is too much high in most of the cases.

Again, in many cases, it contains time constants which are too short to be taken into account in fundamental frequency simulations [7-8]. In another cases, by loosing of energy, some researchers have proposed new pitch controller as well as governor control for minimizing frequency fluctuation [13]. Again, fuzzy logic based pitch controller with energy capacitor system is used which is also costly and can be maintained up to a certain level [14]. Another pitch controller is designed to control frequency fluctuation [15] which has also limitation in controlling frequency fluctuations.

Considering all the facts above, a great deal of research has been focused on designing a new pitch controller to reduce the costs of wind power for smoothing the output power and as well as the frequency fluctuation. Finally, this paper presents a new pitch control system using the real wind speed data with rotor speed and frequency for smoothing the wind generator output fluctuations.

2 SYSTEM MODEL

The model system shows in Fig 1 is used for the simulation analyses for the wind generator output stabilization purposes. The model system used for simulation consists of a wind farm (WF), two thermal power generators (cylindrical type synchronous generators, SG2 and SG3), a hydro power generator HG (a salient pole synchronous generator, SG1), a nuclear power generator NG (a cylindrical type synchronous generators, SG4), and a load.

The considered wind farm consists of five wind power generators (squirrel cage induction machines, IG_n, n=1,2,3,4,5) are considered as the fixed-speed wind generator, whose are connected to the wind farm terminal. SG1 and SG3 are operated under Load Frequency Control (LFC), SG2 is under Governor Free (GF) control and SG4 is under Load Limit (LL) operation. To control frequency fluctuations, LFC is used with a long period more than a few minutes, and to control fluctuations, GF is used with a short period less than a minute and to maintain output constant power, LL is used. Two capacitor banks, QWF and

Q Load are considered. In order to compensate the reactive power demand of wind farm at steady state, QWF is used at the terminal of wind farm and, the value of the capacitor is chosen for maintaining the power factor of the wind power station unity during the rated operation. Q Load is used at the terminal of load to compensate the voltage drop by the impedance of transmission lines. Core saturations of induction generator and synchronous generators are not considered. The initial power flow and initial conditions are shown in Table I. Parameters of IGs and SGs are shown in Table II.

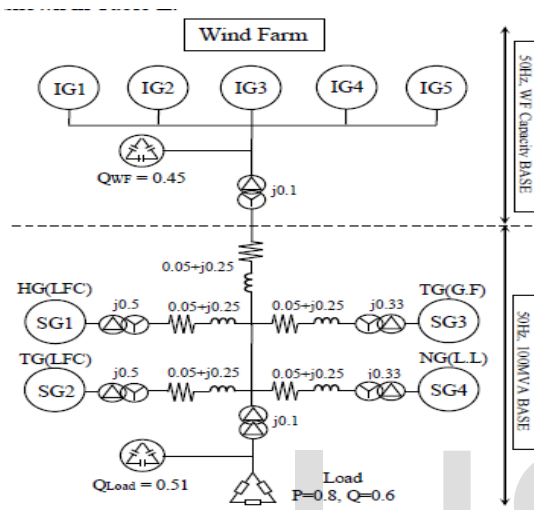

Fig 1: Model System

Table-I
Initial conditions

	IG	SG1	SG2,SG3,SG4
P	0.1	1.00	1.00
V	1.0	1.05	1.05
Q	0.0		
s (slip)	-1.733%		

Table-II

Induction Generator				
Squirrel cage type (IGn,n=1,2,,,5)				
MVA	2 (each)			
R ₁ (pu)	0.01			
X ₁ (pu)	0.10			
X _m (pu)	3.5			
R ₂₁ (pu)	0.035			
X ₂₁ (pu)	0.03			
R ₂₁ (pu)	0.014			
X ₂₁ (pu)	0.098			
2H (sec)	1.5			
Synchronous generator				
	Salient pole type (SG1)	Cylindrical type		
		SG4	SG3	SG4
MVA	20	30	20	30
X _d (pu)	1.2	2.11		
X _q (pu)	0.7	2.02		
H (seconds)	2.5	2.32		

3 Modeling of SYNCHRONOUS GENERATOR

3.1 Governor for hydro, thermal and nuclear generators [2, 9, 12]:

The governor unit automatically adjusts the rotational speed of the turbine is automatically adjusted by the governor unit and the generator output is controlled. The turbine is operated at a constant rotational speed during the period when the generator load is constant. However, when the load changes, balance between the generator output and the load is not maintained, and the rotational speed changes, also. When the load is removed, the governor detects the increase of the rotational speed, and the valve is closed immediately so that an abnormal speed increase of the generator can be prevented. The governor models used in the simulation analysis for hydro, thermal and nuclear generators are shown in Figs. 2(a) and 2(b) [1].

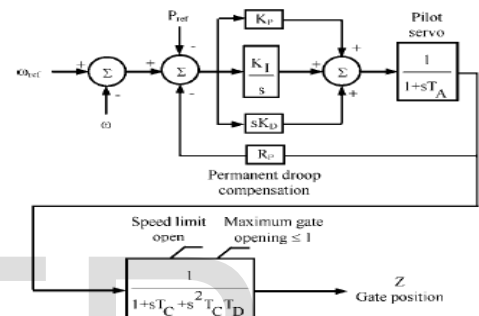

Fig 2(a): Hydro governor[2]

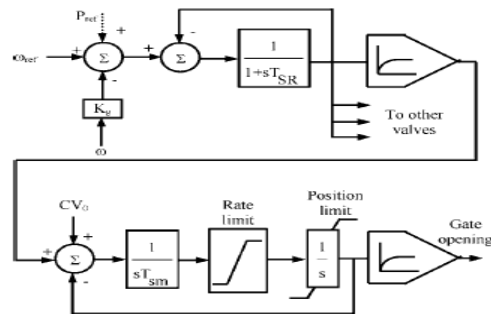

Fig 2(b) :Thermal and Nuclear governor[1]

3.2 Automatic voltage regulator (AVR) [12]:

For maintaining the voltages of the synchronous generator constant, an automatic voltage regulator (AVR) is needed. A simple AVR model is considered for the simulation analysis which consists of a first order system. AVR model is shown in following Fig 3

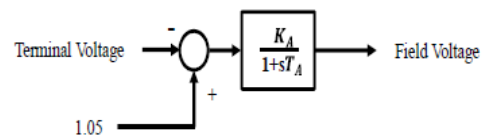

Fig 3: AVR model

3.3 Load Frequency Control Model [1, 12]:

The output power signal is sent to each power plant when frequency deviation is detected in the power system in the load frequency control model. Then, the governor output of each power plant is changed according to the LFC signals, and the power plant output is changed. The LFC model used here is shown in Fig 4, where T_{c2} (the LFC period) = 200 seconds, ω_c (LFC frequency) = $1/T_{c2} = 0.005$ Hz, ζ (damping ratio) = 1. The frequency deviation is input into a low pass filter (LPF) to remove fluctuations having a short period, because the LFC is used to control frequency fluctuations having a long period. By using trial and error method, the parameters are chosen to obtain the better performance from the system.

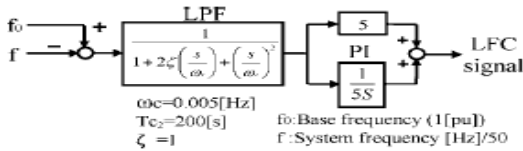

Fig 4: LFC model

4 MODELING OF WIND TURBINE [2]

The mathematical relation for the mechanical power extraction from the wind can be expressed as follows:

$$P_w = 0.5 \rho \pi R^2 V_w^3 C_p(\beta, \lambda)$$

Where, P_w is the extracted power from the wind, r is the air density (in kg/m^3), R is the blade radius (in meters), and C_p is the power coefficient, which is a function of both the tip speed ratio, λ , and the blade pitch angle, β (in degrees), where the tip speed ratio is given as follows:

$$\lambda = \frac{V_w}{\omega_B}$$

And the C_p equation is as given as follows:

$$C_p = (1/2)(\lambda - 0.022\beta^2 - 5.6)e^{-0.17\lambda}$$

Where, V_B is the rotational speed of the turbine hub (in rad/seconds). Here, the wind speed, V_w , is given in miles per hour.

5 PITCH CONTROLLER MODEL

In order to sense the increased velocity when the wind power is beyond the rated level and maintain the output power fluctuation in an acceptable range, pitch controller is used but when the wind speed is below the rated speed, the pitch angle is zero. This paper proposes a new pitch controller model which is shown in the Fig 6. Here, a proportional controller with frequency deviation from rated one is used as input and the contribution is added to the standard pitch controller signal from the rotor speed of the wind turbine. The newly designed pitch controller also features a numerical constant for the purpose of adjustment. With the increases of the wind speed, the pitch angle increases and controls the frequency fluctuations within ± 0.13 [Hz] as well as controls the output power fluctuation rather than the conventional pitch controller

shown in the Fig 5. On the other hand, the energy also becomes very useful using the proposed pitch controller. For the simplicity, a first order time delay system is used with a time constant of $T_w = 0.3s$. Due to the mechanical limitations, weight of blade and rotational inertia of blade, the pitch angle cannot change instantly, a rate limiter of $6^\circ/sec$ is used.

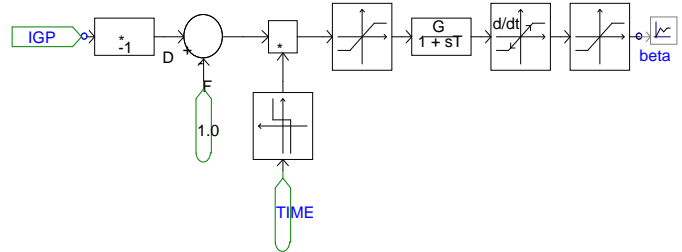

Fig 5: Conventional pitch controller

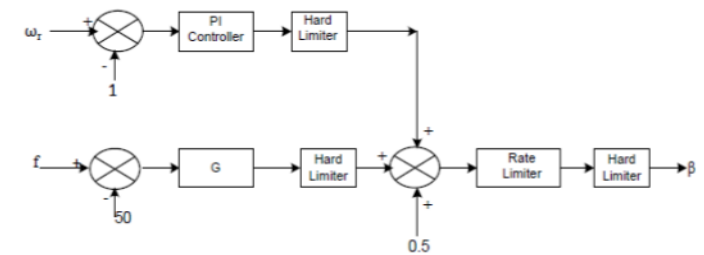

Fig 6: Proposed pitch controller

6 SIMULATION ANALYSES

For obtaining the frequency fluctuation of power system by using the real wind speed data, simulation analyses have been performed using PSCAD/EMTDC [6] for 600 sec. The performances of power system have been compared using proposed and conventional pitch controller. Fig. 7 shows the wind data which is in all the wind generators. Here, Fig 8 & Fig 9 shows the blade pitch angle of the conventional pitch controller and the proposed pitch controller for the different generators. It is observed from Fig. 10 that the fluctuation of frequency is within ± 0.11 Hz which is in the range of permissible power system frequency of 50 ± 0.2 Hz and from this observation, we can say that the result is good very much. The output power of the total wind farm is shown in Fig 11 and from which it is clear that the output power is controlled and is much higher in proposed pitch controller rather than in conventional pitch controller.

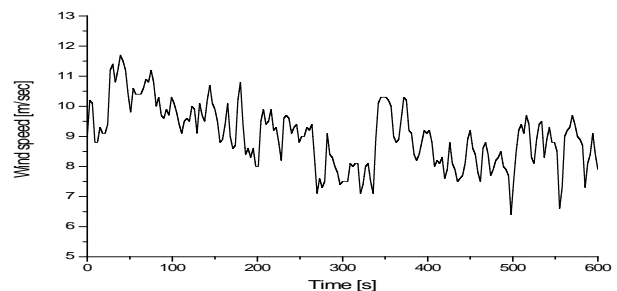

Fig 7: Real wind speed data (for IG1,IG2,IG3,IG4,IG5)

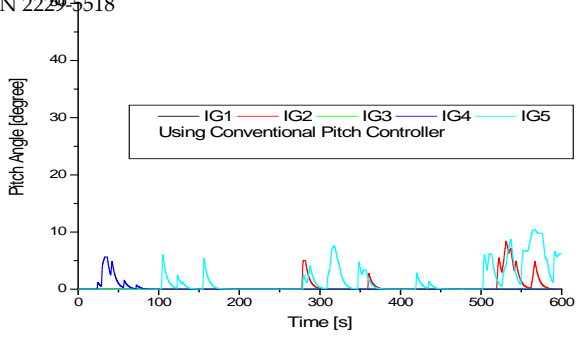

Fig 8: Pitch Angle responses of IG1-IG5

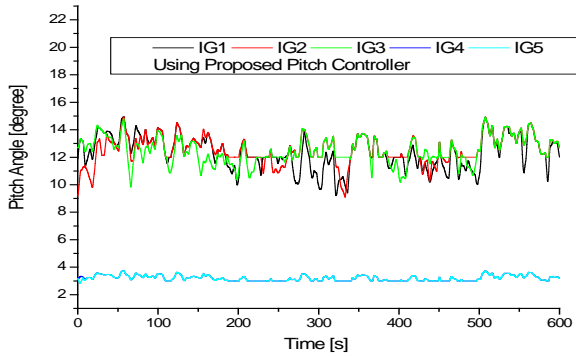

Fig 9: Pitch Angle responses of IG1-IG5

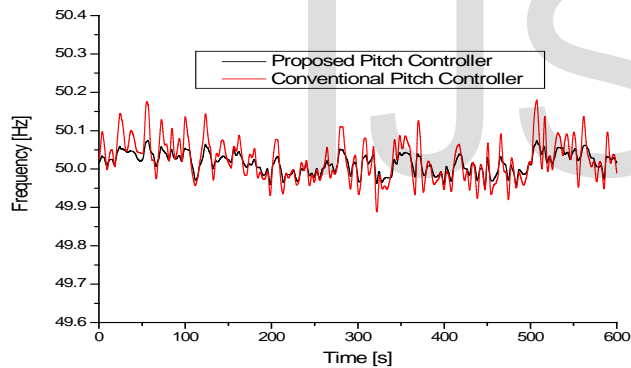

Fig 10: Frequency Fluctuation of the system

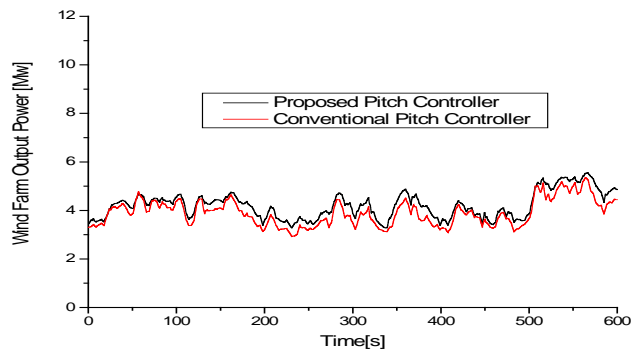

Fig 11: Output power of the Wind farm.

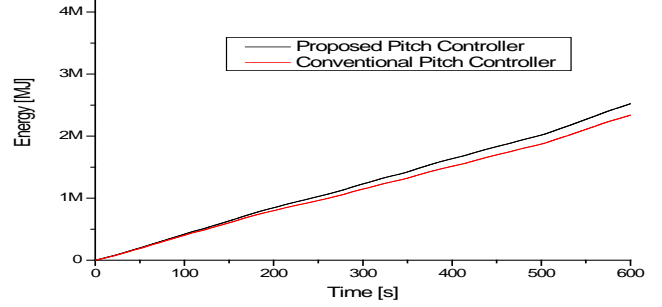

Fig 12: Energy responses

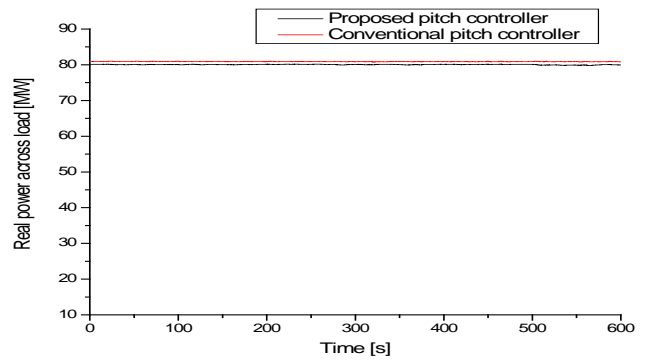

Fig 13: Real power across load [MW]

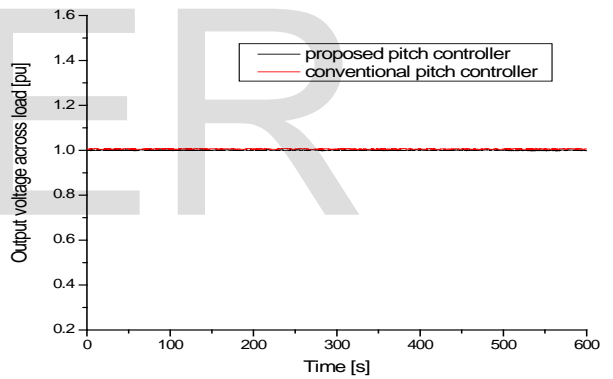

Fig 14: Voltage across load [pu]

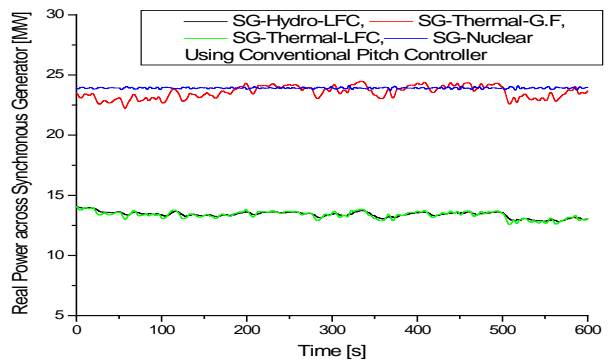

Fig 15: Real power across synchronous generators

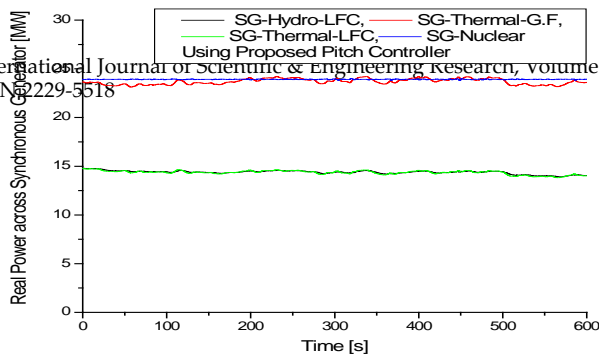

Fig 16 : Real power across synchronous generators

The energy generation from the wind power system using both the pitch controllers is shown in Fig 12 and it is clear that the energy loss is less in proposed frequency controlled pitch controller comparing with the conventional one.

The real power and the voltages across the load are shown in Fig 13 & 14 and the result is good in proposed pitch controller rather than the conventional pitch controller. On the other hand Fig 15 and 16 show the real power supplied by the synchronous generators for the both pitch controllers and it is seen that a good result obtained in the proposed pitch controller. So, the frequency can be controlled with the increased total capacity of wind power generation.

7 DISCUSSION

According to general electric utility industry law in Japan the acceptable frequency deviation which is ± 0.2 [Hz], it is seen that the deviation of the frequency of the wind farm is within the range of ± 0.2 [Hz]. This deviation of frequency is controlled within ± 0.12 [Hz] which is shown from Fig 10 by the newly proposed pitch controller. As a result, we seen that the proposed frequency controlled pitch controller can be considered sufficiently effective for minimizing the frequency fluctuations of the wind power system as well as smooth power can be delivered to the customers rather than the conventional one.

8 CONCLUSION

Due to the continuous variation of wind speed, wind farm output power as well as frequency fluctuations occurred, which also creates difficulties for the power grid companies to provide the constant power. By using the proposed pitch controller, the output power as well as frequency can be controlled effectively. Thus a large number of wind farms can be added with the utility network. So it is more active and effective than conventional pitch controller and also cost effective rather than using any energy storage devices.

REFERENCES

[1]. S.M. Muyeen, H.M. Hasanien, J. Tamura, "Reduction of frequency fluctuation for wind farm connected power systems by an adaptive artificial neural network controlled energy capacitor system" IET Renewable Power Generation, doi: 10.1049/iet-rpg.2010.0126, 19th March 2012.
 [2]. M. R. I. Sheikh, S. M. Muyeen, R. Takahashi and J. Tamura "Smoothing control of wind generator output fluctuations by PWM voltage source converter and chopper controlled SMES", Published

online in Wiley Inter Science (www.interscience.wiley.com). DOI: 10.1002/etep.469.

[3]. T. Kinjo, T. Senjyu, N. Urasaki, and H. Fujita, "Terminal-voltage and output-power regulation of wind-turbine generator by series and parallel compensation using SMES," IEE Proc.-Gener. Transm. Distrib., vol. 153, no. 3, pp. 276-282, May 2006.
 [4]. Mohd. Hasan Ali, *Junji Tamura, and Bin Wu, "SMES Strategy to Minimize Frequency Fluctuations of Wind Generator System,"
 [5]. M.R.I Sheikh, S.M. Muyeen, R. Takahashi, T. Murata, and J. Tamura, "Minimization of fluctuations of output power and terminal voltage of wind generator using STATCOM/SMES," IEEE Bucharest. Bucharest, pp. 1-6, 28 June - 02 July 2009.
 [6]. PSCAD/EMTDC Manual, Manitoba HVDC Research Center (1994).
 [7]. Z. Chen and E. Spooner, "Grid power quality with variable speed wind turbines," IEEE Trans. Energy Conversion, vol. 16, pp. 148-154, June 2001.
 [8]. A. S. Neris, N. A. Vovos, and G. B. Giannakopoulos, "A variable speed wind energy conversion scheme for connection to weak AC systems," IEEE Trans. Energy Conversion, vol. 14, pp. 122-127, Mar. 1999.
 [9]. Standard models of electrical power system: Technical Report Inst. Electrical Engineers of Japan (IEEJ), 1999, pp. 1-82 754
 [10]. Heier S. Grid Integration of Wind Energy Conversion System. John Wiley & Sons Ltd.: Chichester, UK, 1998.
 [11]. Wasynczuk O, Man DT, Sullivan JP. "Dynamic behavior of a class of wind turbine generator during random wind fluctuations." IEEE Transactions on Power Apparatus and Systems 1981; PAS-100(6): 2845-2873.
 [12]. M.R.I. Sheikh, R. Takahashi, and J. Tamura, "Study on frequency fluctuations in power system with a large penetration of wind power generation," Ener. J, vol.12, pp. 77-86, 2011.
 [13]. Md. Amzad Hossain "Output Fluctuations Minimization of Wind Integrated Hybrid Power System by Co- ordinate Control of Governor and Blade" a M. Sc. Thesis, October 2014, RUET.
 [14]. Rashad M. Kamel*, Aymen Chaouachi, Ken Nagasaka¹, "Wind power smoothing using fuzzy logic pitch controller and energy capacitor system for improvement Micro-Grid performance in islanding mode". Energy 35 (2010) 2119-2129, 2010 Elsevier Ltd .
 [15]. Takuya Yamazaki*, Rion Takahashi*, Toshiaki Murata*, Junji Tamura*, Masahiro Kubo**, Yoshiharu Matsumura**, Akira Kuwayama**, and Takatoshi Matsumoto**, "Smoothing Control of Wind Generator Output Fluctuations by New Pitch Controller".

IJSER